



DESIGN NOTES

Low Dropout 550kHz DC/DC Controller Operates from Inputs as Low as 2V – Design Note 208

San Hwa Chee

The LTC[®]1622 is a versatile high efficiency step-down controller that easily meets the size requirements of handheld portable applications with its small MSOP package. High frequency of operation (550kHz) allows the use of small magnetics, providing a complete power solution while occupying only a small amount of area. For even smaller magnetics, the LTC1622 can be synchronized up to 750kHz. Its wide operating input voltage range (2V to 8.5V) allows the part to be powered from a single or two lithium-ion batteries or 2- to 6-cell NiCd and NiMH battery packs.

The LTC1622 uses a constant frequency, current mode architecture, that provides excellent AC and DC load and line regulation. Its OPTI-LOOP[™] compensation allows the transient response to be optimized while removing the constraints placed on C_{OUT}, such as limits on low ESRs. Burst Mode[™] operation enhances efficiency at low load current while 100% duty cycle allows low dropout for extended operating time in battery-operated systems. Peak inductor current is set by an external sense resistor, allowing the design to be optimized for each specific application.

2.5V, 4A Buck DC/DC Converter

Figure 1 shows an application that can be used to power a handheld computer. The sense resistor has been selected to ensure low dropout operation while providing an

output current of 4A. For short-circuit protection, a low cost diode, D2, is connected between the I_{TH} pin and V_{OUT} providing current foldback.

In addition, the LTC1622 operating frequency will be reduced to 110kHz when the voltage at the feedback pin drops below 0.3V. This feature ensures that all energy in the inductor will be completely dissipated at the end of each cycle, preventing inductor current runaway.

Due to a large amount of current that flows through the external P-channel MOSFET in this application, it is imperative that the MOSFET has proper heat sinking to thermally conduct heat away.

Figure 2 shows the efficiency curves. At 3V input, 90% efficiency is obtained between load currents of 0.5A to 2A. For load currents between 0.8A to 4A, the efficiency is at or above 85%.

Figure 3 shows the dropout characteristic of the circuit in Figure 1 and Figure 4 shows the load step response from 0.1A to 4A. To ensure the output voltage deviates less than 100mV during a load step, a low ESR output capacitor is chosen for this circuit. For a lower voltage deviation, a similar capacitor can be connected in parallel with the existing one.

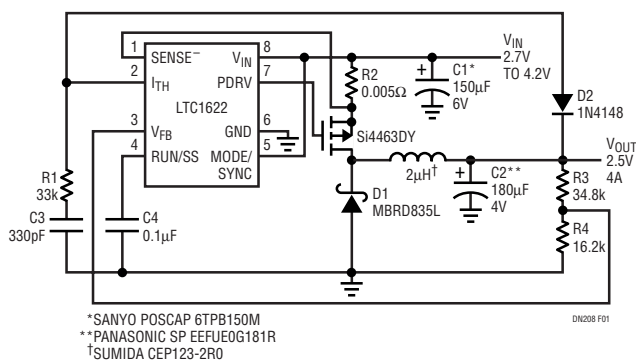

Figure 1. 2.5V, 4A Step-Down Converter

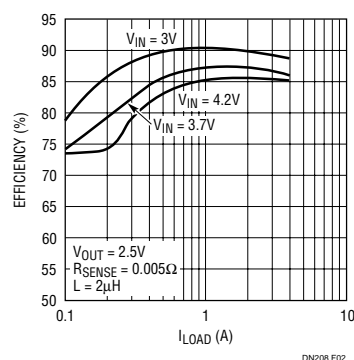

Figure 2. Efficiency vs Output Load Current

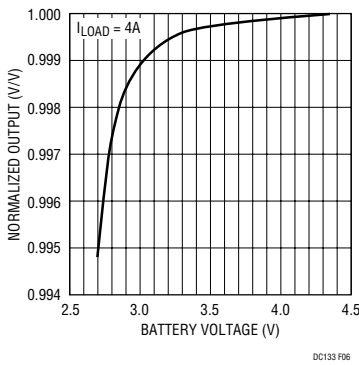

Figure 3. Drop-out Characteristic of Figure 1

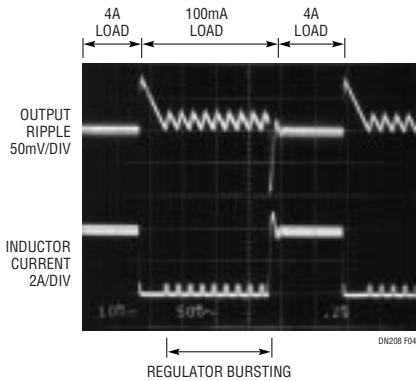

Figure 4. Load Step Response (0.1A to 4A)

“Zeta” Step-Up/Step-Down Converter

Applications when the input voltage ranges between 4.2V to 2.7V (from a single lithium-ion) and the output is 3.3V, a zeta converter is needed. A zeta converter will step down the input when its input voltage is greater than the output voltage and step up the input voltage when input falls below the output voltage. Figure 5 shows a circuit with a capability of supplying 1A of output current. Note that inductors L1A and L1B are actually in a single package and they are connected in the polarity indicated. Again, diode D2 is used for limiting the short circuit current. Once again be sure to properly allow adequate copper area by the MOSFET to conduct heat away.

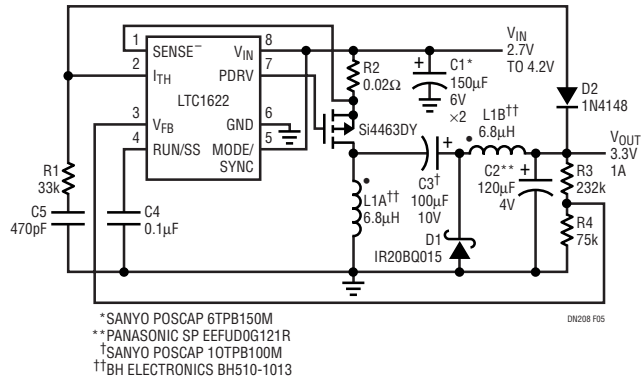

Figure 5. Zeta Converter (3.3V, 1A)

Figure 6 shows its efficiency for input voltages of 3V, 3.7V and 4.2V. Figure 7 shows the load step response from 50mA to 700mA. A single low ESR output capacitor is used to maintain low output voltage deviation during the load step.

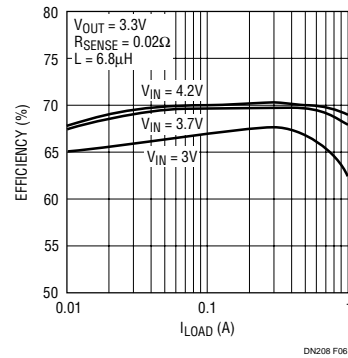

Figure 6. Efficiency vs Output Load Current

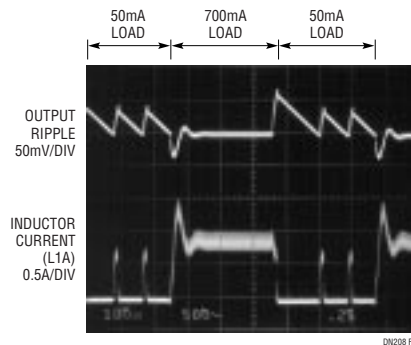

Figure 7. Load Step Response (50mA to 700mA)

Data Sheet Download

<http://www.linear-tech.com/go/dnLTC1622>

For literature on our DC/DC Controllers, call **1-800-4-LINEAR**. For applications help, call (408) 432-1900, Ext. 2593